

Eva

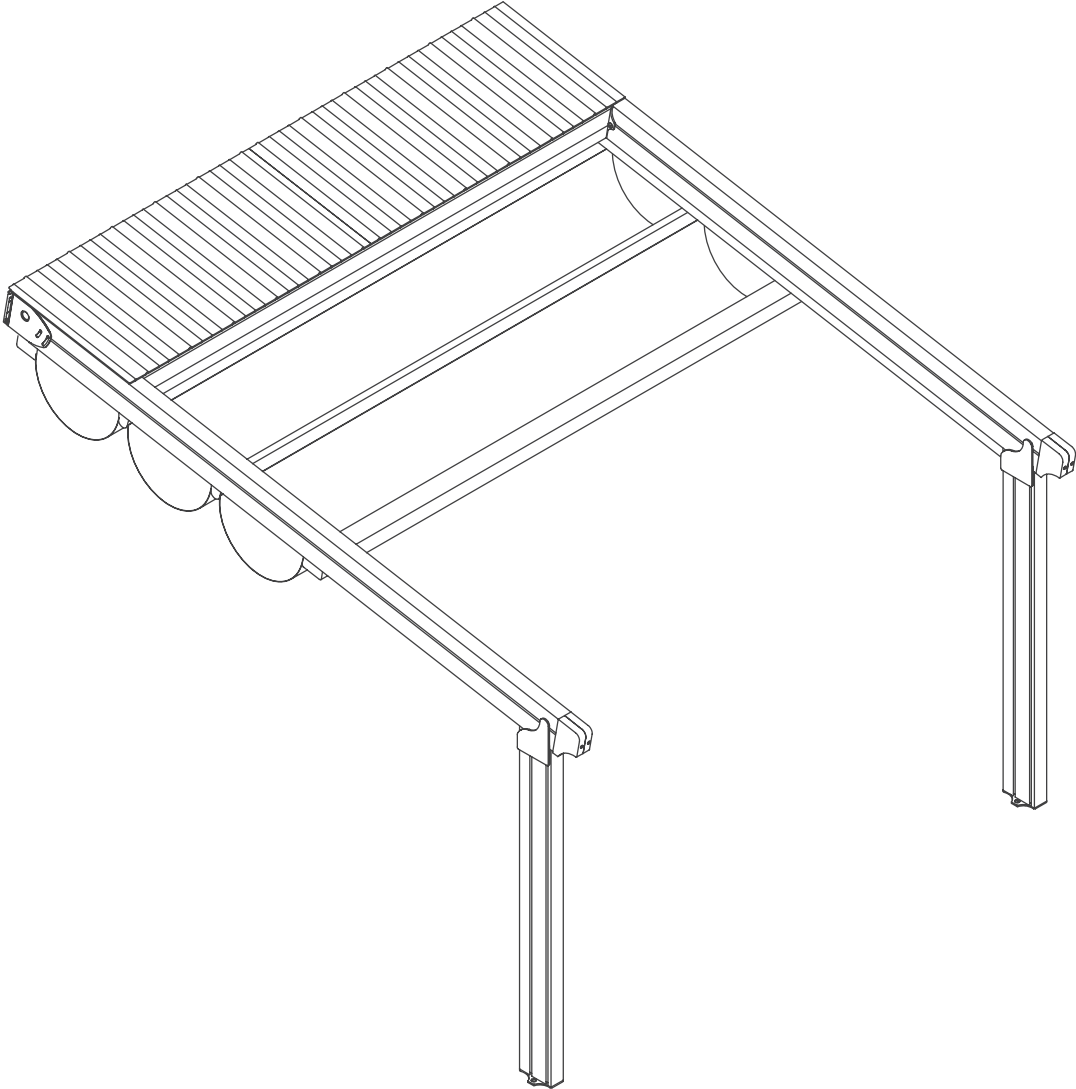

Eva retractable pergola system

The EVA retractable pergola system provides an elegant outdoor covering to allow outdoor areas to be used in even the worst of weather conditions. The system offers a wind rating up to Beaufort class 11 (up to 117km/h) and is designed to stand up to even the worst of conditions rain, hail or shine.

The system is manufactured to size using high grade 6063 extruded aluminium profiles finished with thermosetting powder coating which provides superior overall performance for exterior product applications. All bolts, screws and pins are high grade stainless steel to ensure extended system life.

The EVA rafter profiles (54mm x 135mm) have been designed with unique water guard side channels and allow for projections up to 6m per system. Widths are customised according to site requirements and available in any size up to 13m. The EVA system offers up to 78sqm of protection at the touch of a button but when required linking multiple systems is also possible and made easy by our patented storm channel joining system that ensures 100% waterproof join every time.

Remote controlled motorisation is provided by utilising European technology through a custom built direct drive motor system to ensure smooth and quick operation at 26RPM. The optional hi powered LED-TEC lighting system provides a practical touch of class and when coupled with a remote dimming controller allows the user to change the mood to suit the surrounding environment.

The heart of the system is driven by multiple Suntech F3 eight wheel slider carriages (each F3 slider carriage has a load limit of 600kgs) that incorporates a triple layer barrier system and works in conjunction with a timing belt that has been reinforced with multiple internal stainless steel cables to provide a pulling strength of over 966kg. It's this tension that is applied to the fabric membrane to allow an angle of 6 degrees fall possible and ensure all water drains away.

The fire rated and 100% waterproof architectural membrane is available in a range of colours in both opaque and transparent that provides maximum stability and resistance to temperature, moisture and dirt. It does not shrink or bag, and the acrylic top coating makes it very easy to clean for years to come. When not in use the fabric is neatly retracted under the systems hood to provide protection from the elements when not required.

To ensure the highest level of protection Suntech systems focus on all the details, this is why all Suntech systems come standard finished with Stormguard soft touch edge seal on all parameters. Stormguard provides the ultimate protection against rain and draught intrusion around the outside of the system and is only available on our systems. Stormguards soft touch edge seal is produced from an extra soft & flexible rubber to ensure the best possible protection from the elements.

Eva

One Module

200 cm > 450 cm
One Module with one motor & 2 rafters

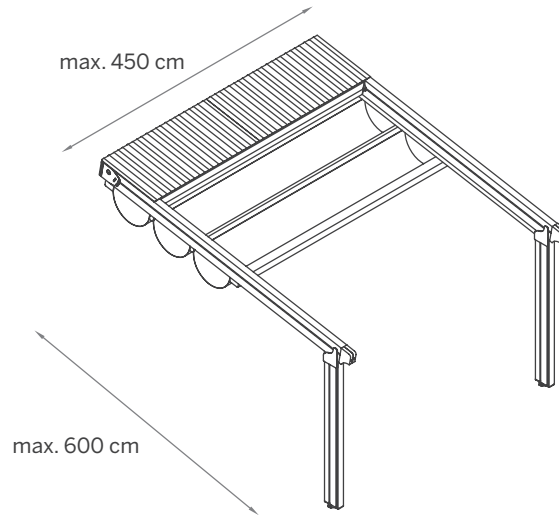

Two Modules

450 cm > 900 cm
Two Modules with one motor & 3 rafters

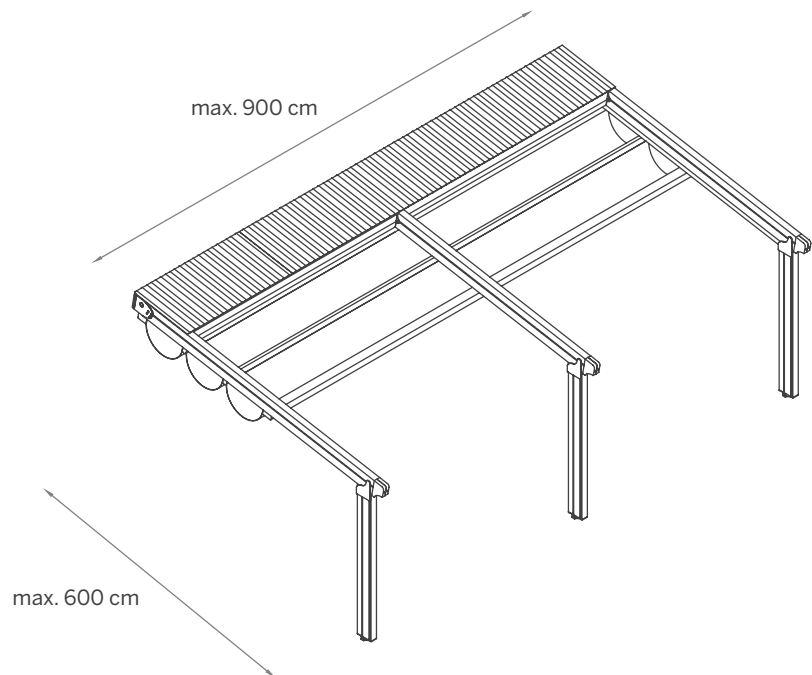

Three Modules

900 cm > 1300 cm

Three Modules with one motor & 4 rafters

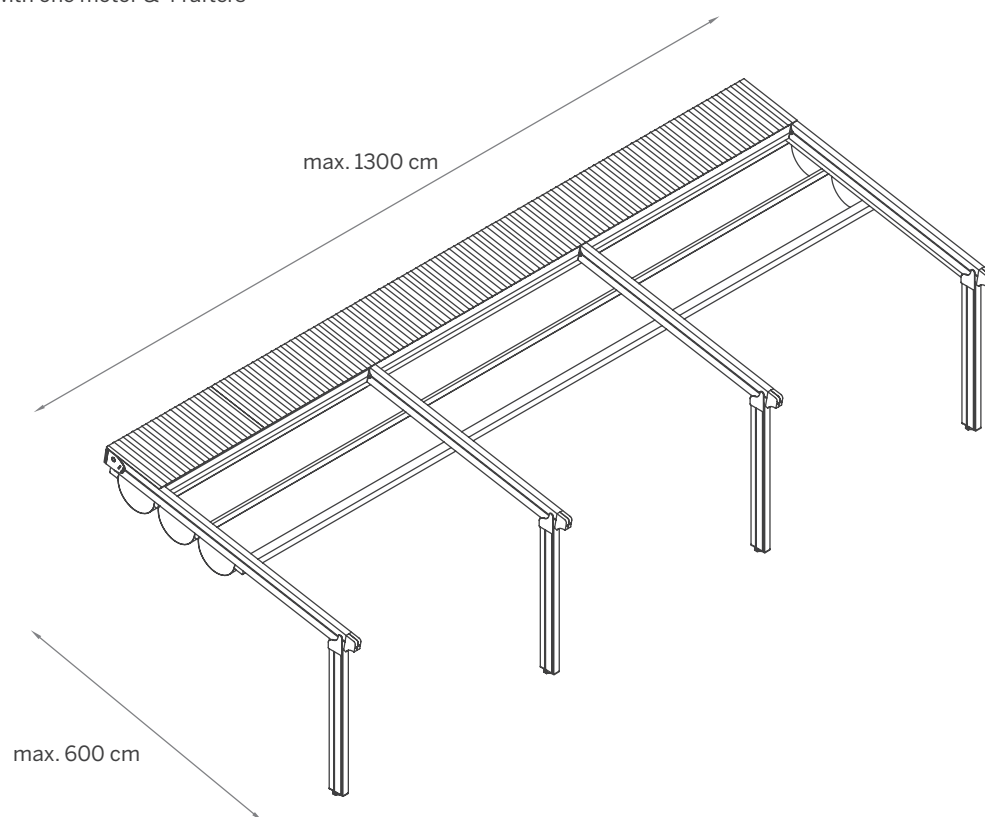

Eva

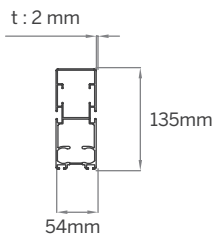
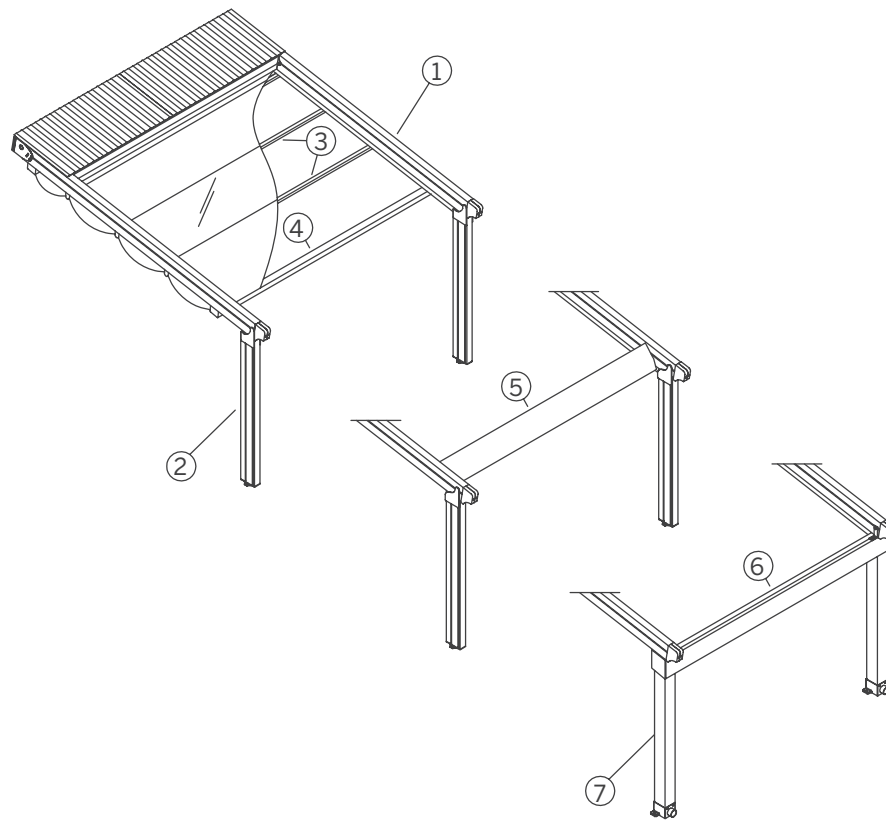

① Rafter

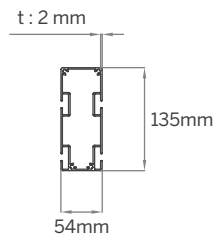

② Post

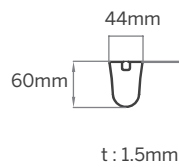

③ Fabric Support (Standart)

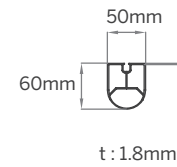

③ Fabric Support (HDD Lux)

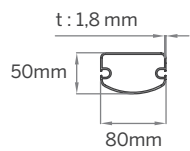

④ Puller Profile (Standart)

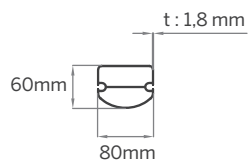

④ Puller Profile (HDD Lux)

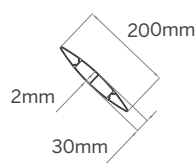

⑤ Aerofoil Louvre

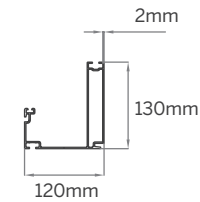

⑥ Gutter

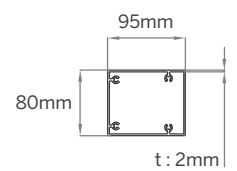

⑦ Post

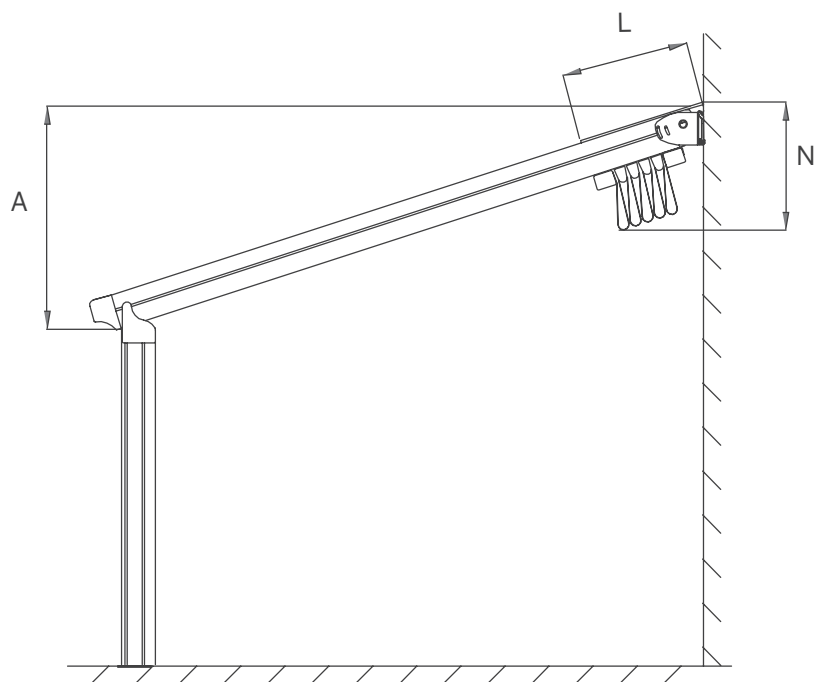

Eva

	Fabric Height	Hood	Fall	Fab.Sup.Profiles
	(N*) mm	(L*) mm	(A*,**) mm	pc*
300	419	613	496	7
350	426	668	557	8
400	433	723	619	9
450	446	833	680	11
500	453	888	742	12
550	459	943	803	13
600	473	1053	864	14

* With min. inclination of 7°. Values can vary by other inclination values.

** +130 mm distance with optional front gutter system.

Eva

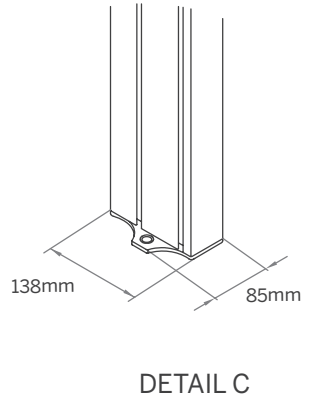
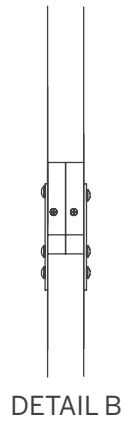
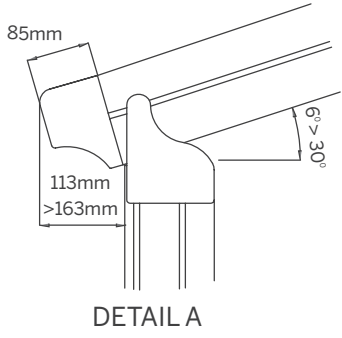
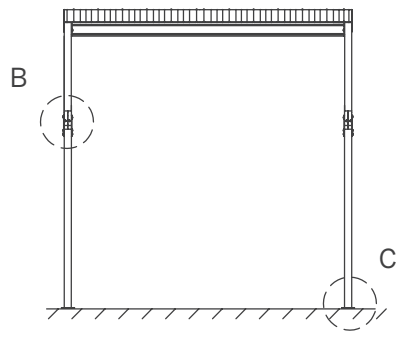
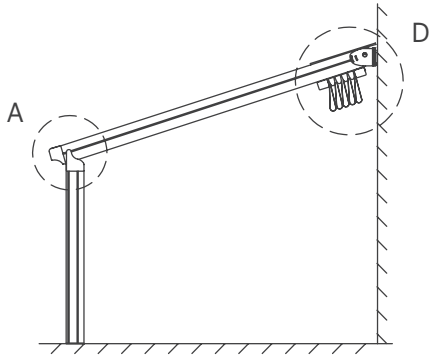

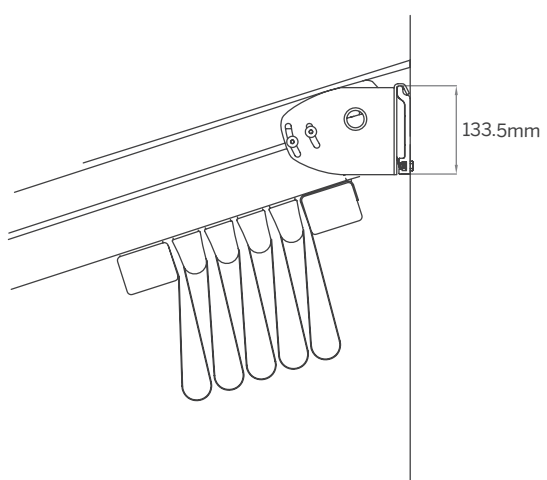

DETAIL D

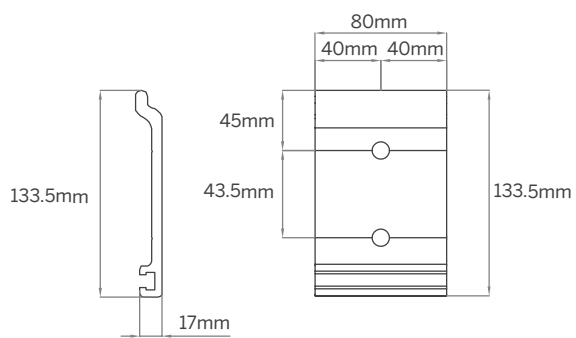

Installation Bracket

Eva

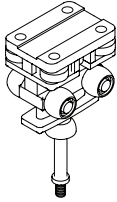

F3 Eight wheel slider

Four horizontal & four vertical rollers working together for perfectly smooth operation every time. The F3 eight wheel system is proven to remove the jamming issue that occurs with the 4 wheel system and can take loads of upto 600KG.

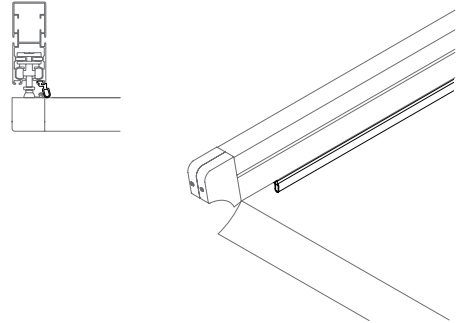

Rafter stormguard edge seal

The rafter Stormguard edge seal stops water from dripping over the side of the system by providing a soft cushioning barrier along the side of the system.

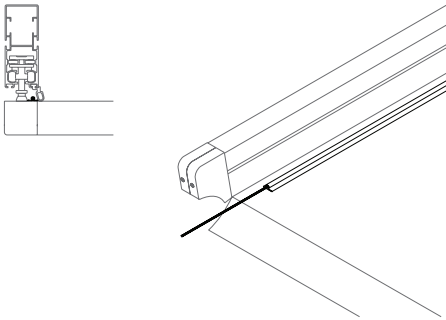

Fabric anti-drop edge cord with electrical cable

The fabric anti-drip edge cord with integrated lighting electrical cable works in conjunction with the Stormguard edge seal to prevent any water leaks over the side of the system.

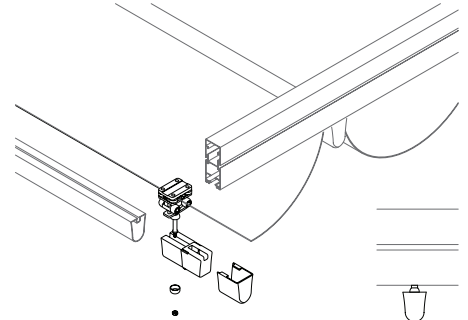

F3 slider and fabric profile assembly

The system has been designed for ease of assembly to save time on installations and reduce the number of staff required.

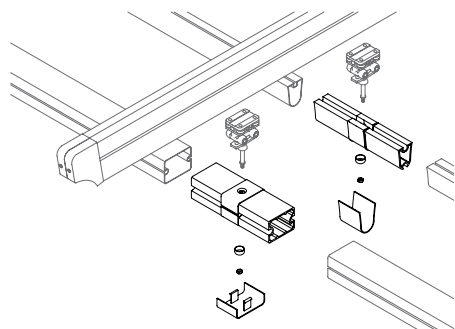

Easy clip intermediate joints (for 2 & 3 module systems)

The Easy clip intermediate joints have been designed for ease of site assembly to save time and reduce the number of staff required.

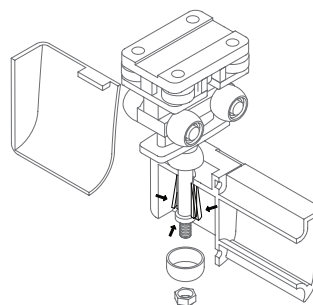

F3 slider easy clip installation

The F3 system has been designed for ease of use, to save time on installations and reduce the number of staff required. Each F3 slider can take loads of upto 600KG once in place.

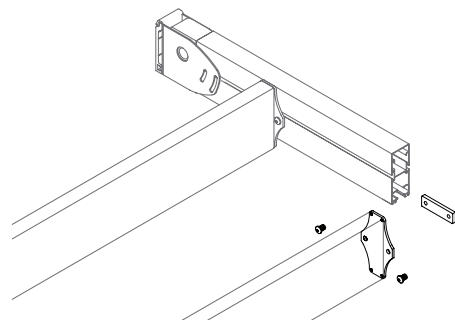

Motorbox support & hood support profile easy installation

Each support profile is easy to install and simple to adjust at the time of installation.

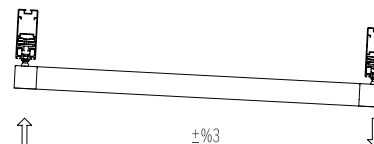

Suntech side fall

System detail for side fall installations.

Eva

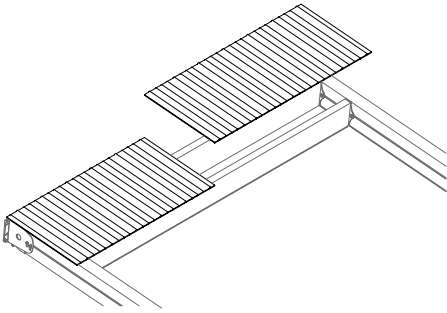

Hood profile sheets

Suntech's hood profile sheets provide an attractive covering solution for the system when not in use. The low profile aesthetic design offer added protection to the system with a chic touch.

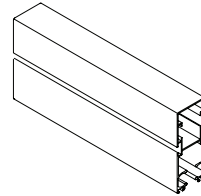

Rafter profile with water guard side channels

The Suntech rafter profiles are designed with water guard side channels for easy installation and to prevent water from entering.

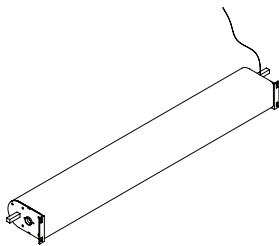

Compact 26rpm direct drive motor box

The Suntech direct drive motor system is a quick and efficient system that drives all conveyer rafters at the same time. The low profile design also allows the fabric to be stored underneath the motor which saves additional space.

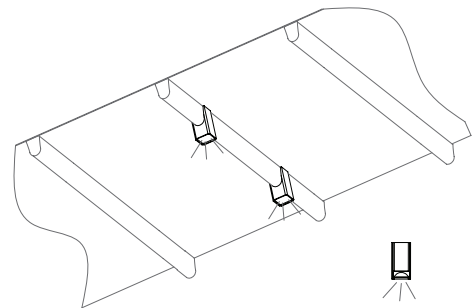

LED-TEC high powered lighting

LED-TEC lighting is a integrated lighting solution that can be added to any Suntech system.

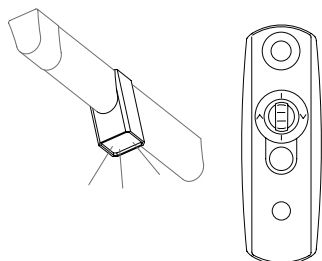

LED-TEC dimmer setup

LED-TEC dimmer lighting is a integrated lighting solution that can be added to any Suntech system.

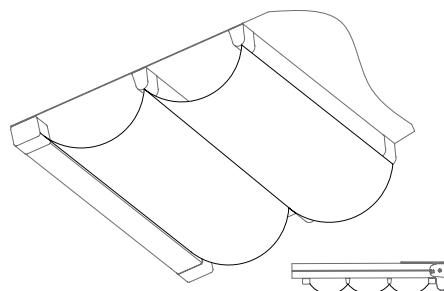

Decorative fabric under layer

The second decorative fabric under layer of fabric can provide an elegant touch of class.

Eva

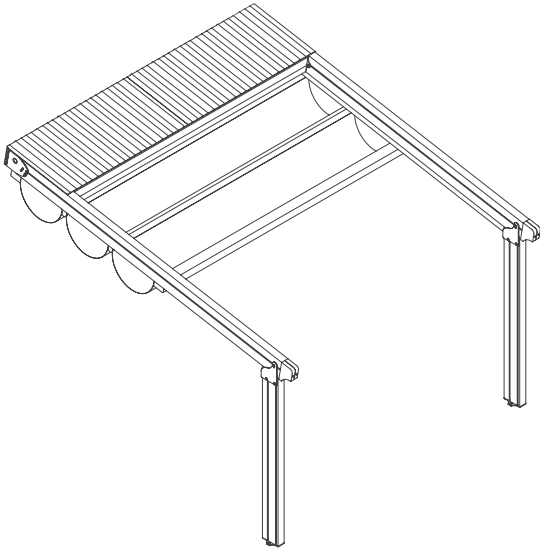

Standart Application

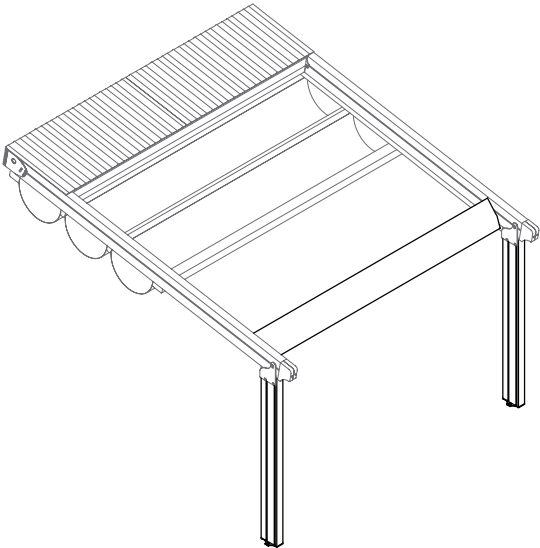

Application With Aerofoil Louvre & Standart Post

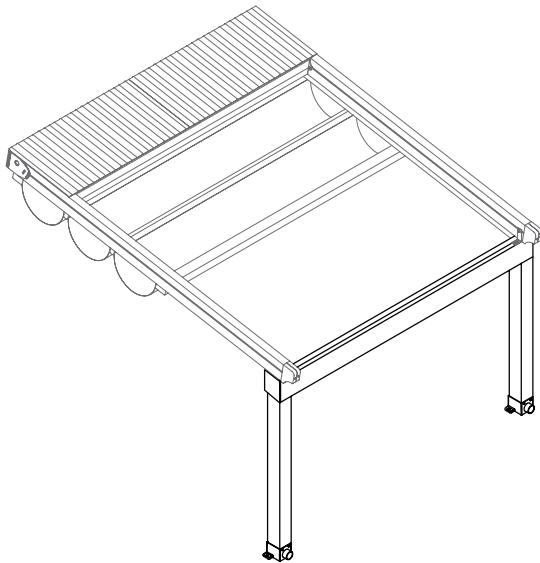

Application With Special Gutter & And Post

type I

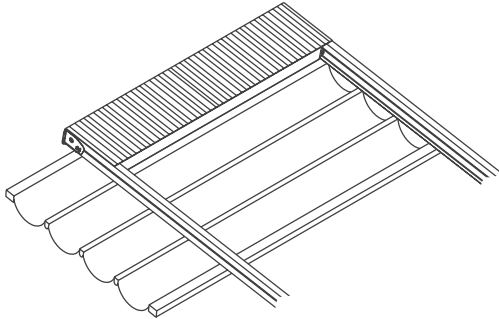

type IV

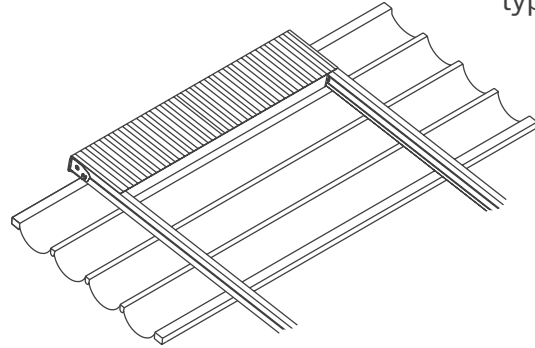

type II

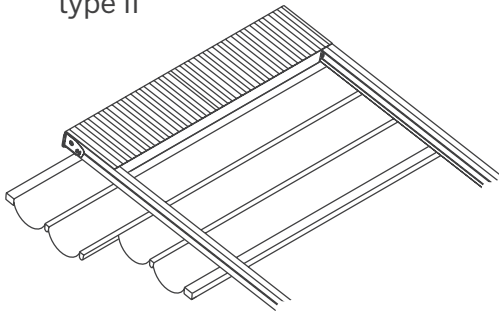

type V

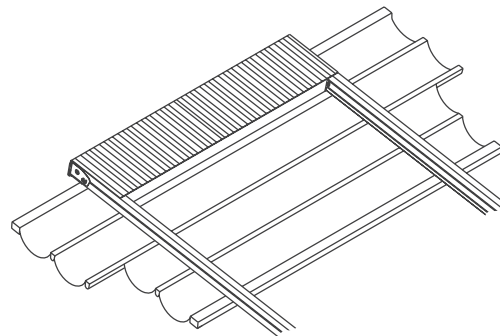

type III

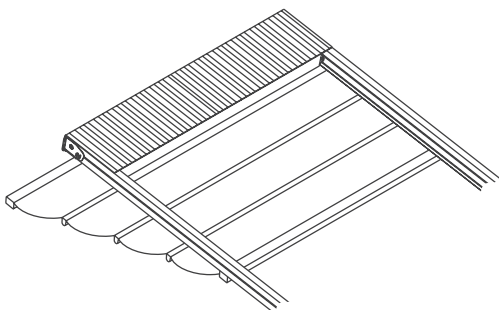

type VI

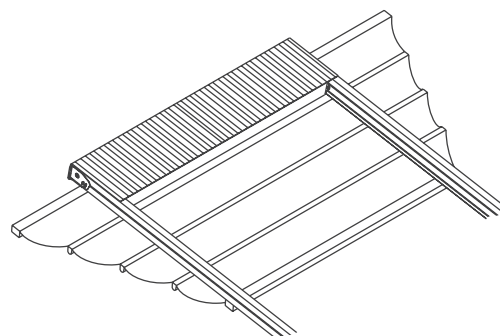

Each system is available with an optional overhang to allow the covered area to protrude past the rafter profile. Site specific overhang solutions such as stepped or wedge shapes are also an effective way to get maximum coverage for your area.

Eva

One Module

200 cm > 450 cm
One Module with one motor & 2 rafters

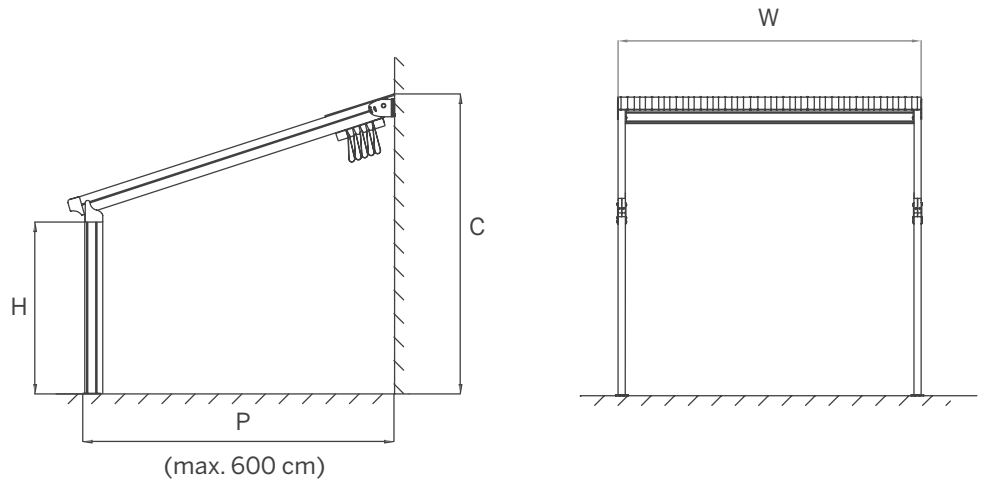

Two Modules

450 cm > 900 cm
Two Modules with one motor & 3 rafters

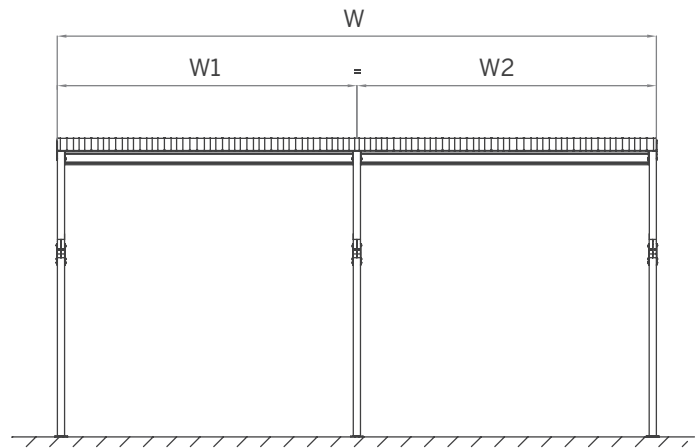

Three Modules

900 cm > 1300 cm
Three Modules with one motor & 4 rafters

